

Riemengetriebene Linearachsen

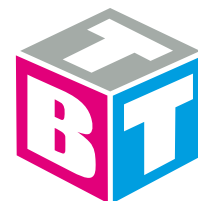













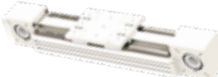



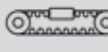





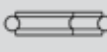











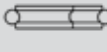
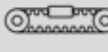



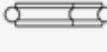





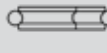
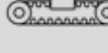



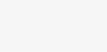
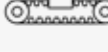

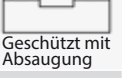

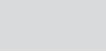
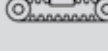
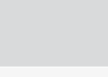





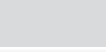

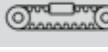
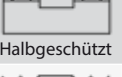



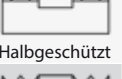

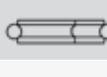

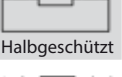

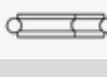



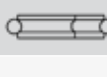
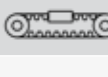
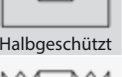

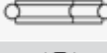
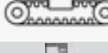

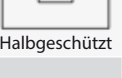

TRAFFA
TECHNISCHES BÜRO

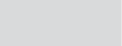

Innovative Antriebslösungen

Der optimale Antrieb individuell für Ihre Anforderung

Riemengetriebe Linearachsen

Referenz		Führung		Antrieb			Korrosionschutz	Schutz
Produktfamilie	Produkt	Kugel-umlauf	Rollenläufer	Zahn-riemen	Kugel-gewinde	Zahn-stange		
Smart System		E-SMART						
		R-SMART						
		R-SMART R						
		S-SMART						 Halbgeschützt
Plus System		ELM PLUS						 Geschützt
		ELM PLUS CR						 Geschützt
		ROBOT PLUS						 Geschützt
		ROBOT PLUS CR						 Geschützt
		ROBOT 2C						 Geschützt
		ROBOT 2C CR						 Geschützt mit Absaugung
Clean Room System		Clean Room System ONE						 Geschützt mit Absaugung
Speedy Rail System		SAB						
Uniline System		ECO Series						 Halbgeschützt
		Uniline A						 Halbgeschützt
		Uniline C						 Halbgeschützt
		Uniline E						 Halbgeschützt
		Uniline ED						 Halbgeschützt
Modline		MCH						 Halbgeschützt
		MCR						 Halbgeschützt
		ZCH						

* Zum Realisieren längerer Verfahrswege/ Hübe sind die Linearachsen in zusammengesetzter Ausführung (Stoßversion) lieferbar.

Größe	Max. Belastung pro Laufwagen [N]			Max. statisches Moment pro Laufwagen [Nm]			Max. Fahrgeschwindigkeit [m/s]	Max. Beschleunigung [m/s ²]	Wiederholgenauigkeit [mm]	Max. Weg bzw. Hub (pro System) [mm]
	F _x	F _y	F _z	M _x	M _y	M _z				
30-50-80-100-144	11025	464000	464000	10000	63684	63684	4	50	± 0,1	10900
120-160-220-230-280	11025	44972	44972	6296	9294	9294	4	50	± 0,1	11045
140-170-220-230-280	11025	44972	44972	6296	9294	9294	8	20	± 0,1	11045
50-65-80	2523	55400	55400	700	4044	4044	4	50	± 0,05	2000
50-65-80-110	4980	129400	129400	1392	11646	11646	5	50	± 0,05	5882
50-65-80-110	4980	129400	129400	1392	11646	11646	5	50	± 0,05	5882
100-130-160-220	9545	258800	258800	22257	28986	28986	5	50	± 0,05	5900
100-130-160-220	3818	258800	258800	22257	28986	28986	5	50	± 0,05	5460
100-130-160-220	3818	258800	258800	22257	28986	28986	5	50	± 0,05	5460
50-65-80-110	4980	104800	104800	1126	10532	10532	5	50	± 0,05	6000
60-120-180-250	4980	5431	5431	558	597	644	10	10	± 0,02	6970
60-80-100	4565	55400	55400	700	5485	5485	5	50	± 0,05	6830
40-55-75	24560	11000	3710	87,2	6336	18788	7	15	± 0,1	7500
55-75	2940	1500	8700	170,4	13154	2268	5	15	± 0,1	7500
55-75	24560	11000	7420	171	12673	18788	5	15	± 0,1	7500
75	19360	11000	17400	800,4	24917	15752	5	15	± 0,1	7500
65-80-105	3984	55400	55400	700	5983	5983	5	50	± 0,1	7200
65-80-105	3984	55400	55400	700	5983	5983	5	50	± 0,1	7200
60-90-100-170-220	7470	189200	189200	13665	38691	38691	4	25	± 0,1	2500

Quelle: Rollon GmbH, Düsseldorf

Zweiachssysteme



Zweiachssysteme

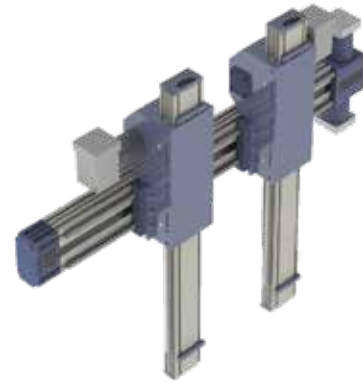

Dreiachssysteme

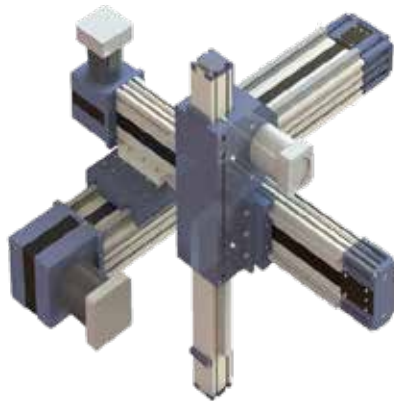

Dreiachssysteme

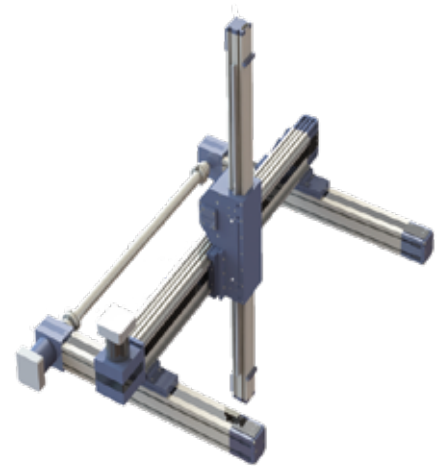

Dreiachssysteme

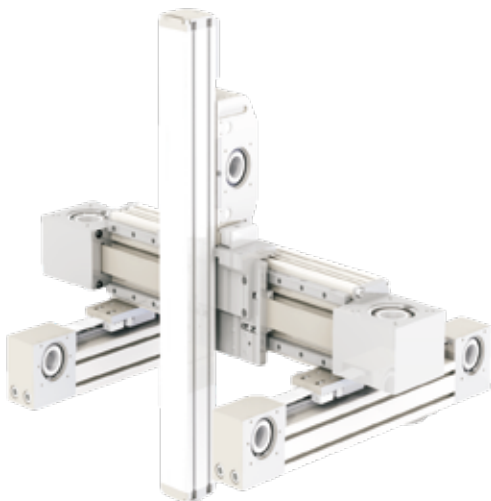

Dreiachssysteme

